



Genomic DNA from plant

User manual

NucleoSpin® 8 Plant II

NucleoSpin® 8 Plant II Core Kit

February 2012/Rev.02

Table of contents

1	Components	4
1.1	Kit contents	4
1.2	Reagents to be supplied by user	5
2	Product description	6
2.1	The basic principle	6
2.2	Kit specifications	6
2.3	Required hardware	7
2.4	Recommended accessories for use of the NucleoSpin® 8 Plant II Core Kit	8
2.5	Automated processing on robotic platforms	9
2.6	Storage and homogenization of samples	10
2.7	Elution procedures	11
3	Storage conditions and preparation of working solutions	12
4	Safety instructions – risk and safety phrases	13
4.1	Risk and safety phrases	13
4.2	GHS classification	14
5	Protocols	16
5.1	NucleoSpin® 8 Plant II – centrifuge processing	16
5.2	NucleoSpin® 8 Plant II – vacuum processing	21
6	Appendix	27
6.1	Troubleshooting	27
6.2	Ordering information	28
6.3	Product use restriction /warranty	29

1 Components

1.1 Kit contents

REF	NucleoSpin® 8 Plant II	
	12 x 8 preps 740669	60 x 8 preps 740669.5
Lysis Buffer PL1	75 mL	3 x 125 mL
Lysis Buffer PL2 ¹	60 mL	3 x 100 mL
Precipitation Buffer PL3	15 mL	3 x 25 mL
Binding Buffer PC	2 x 30 mL	3 x 110 mL
Wash Buffer PW1	50 mL	2 x 125 mL
Wash Buffer PW2 (Concentrate) ¹	40 mL	200 mL
Elution Buffer PE ²	30 mL	125 mL
RNase A (lyophilized) ¹	15 mg	3 x 30 mg
NucleoSpin® Plant II Binding Strips (dark green rings)	12	60
MN Wash Plate	1	5
Rack of Tube Strips ³ (for lysis and elution)	2	10
Cap Strips	12	60
MN Square-well Block	2	10
Gas-permeable Foil	5	25
User manual	1	1

¹ For preparation of working solutions and storage conditions see section 3.

² Composition of Elution Buffer PE: 5 mM Tris/HCl, pH 8.5

³ 1 rack = 12 strips with 8 tubes each, Cap Strips included

NucleoSpin® 8 Plant II Core Kit	
REF	48 x 8 preps 740467.4
Lysis Buffer PL1	240 mL
Lysis Buffer PL2 ¹	200 mL
Precipitation Buffer PL3	50 mL
Binding Buffer PC	2 x 110 mL
Wash Buffer PW1	2 x 100 mL
Wash Buffer PW2 (Concentrate) ¹	150 mL
Elution Buffer PE ²	100 mL
RNase A (lyophilized) ¹	2 x 30 mg
NucleoSpin® Plant II Binding Strips (dark green rings)	48
User manual	1

1.2 Reagents to be supplied by user

- 96–100 % ethanol

¹ For preparation of working solutions and storage conditions see section 3.

² Composition of Elution Buffer PE: 5 mM Tris/HCl, pH 8.5

2 Product description

2.1 The basic principle

The **NucleoSpin® 8 Plant II** kit is designed for the isolation of genomic DNA from plant materials. After the plant samples have been homogenized, the DNA can be extracted with lysis buffers containing chaotropic salts, denaturing agents, and detergents. The standard isolation ensures the lysis of plant material with the CTAB Lysis Buffer PL1, which is specially developed for plants. In addition, an SDS based lysis buffer, Buffer PL2, is provided as an alternative. However, Buffer PL2 does require a subsequent protein precipitation with potassium acetate. Lysates should be cleared by centrifugation in order to remove polysaccharides, contaminations, and residual cellular debris. The clear supernatant is mixed with Binding Buffer PC to create conditions for optimal binding to the silica membrane in the binding strips. After washing with two different buffers (Buffer PW1 and Buffer PW2) DNA can be eluted in low salt Buffer PE or water and is ready-to-use for subsequent analysis and processing.

2.2 Kit specifications

- **NucleoSpin® 8 Plant II** is designed for the isolation of genomic DNA from plant material.
- **NucleoSpin® 8 Plant II** allows parallel purification of multiples of 8 samples each with up to 100 mg sample per well (wet weight).
- Depending on the individual sample, **NucleoSpin® 8 Plant II** shows yields in the range of 1–30 µg DNA (maximum column capacity is about 30 µg) with an A_{260}/A_{280} ratio between 1.80 and 1.90 and typical concentrations of 100–200 ng/µL. The amount of DNA that can be expected per mg of sample extracted depends on the size and ploidy of the genome. For example, 100 mg fresh wheat with a hexaploid genome (1.7×10^{10} bp) contain 30 µg DNA, whereas the same amount of *Arabidopsis* with a smaller diploid genome (1.9×10^8 bp) yields only 3 µg DNA.
- The eluted DNA is ready-to-use in subsequent reactions like PCR, restriction analysis, etc.
- **NucleoSpin® 8 Plant II** can be processed under vacuum or in a centrifuge.
- Two lysis buffers, based on CTAB (PL1) or SDS (PL2) are provided.
- **NucleoSpin® 8 Plant II** can be used manually with the NucleoVac 96 Vacuum Manifold (see ordering information) or other vacuum devices.

Kit specifications at a glance	
Parameter	NucleoSpin® 8 Plant II
Technology	Silica-membrane technology
Format	8-well strips
Processing	Manual or automated, vacuum or centrifugation
Sample material	20–100 mg plant tissue, plant cells (wet weight)
Fragment size	50 bp–approx. 50 kpb
Typical yield	1–30 µg
A_{260}/A_{280}	1.8–1.9
Elution volume	100–200 µL
Preparation time	60 min/6 strips (excl. lysis)
Binding capacity	30 µg

2.3 Required hardware

NucleoSpin® 8 Plant II can be processed under vacuum or with centrifugation. Certain hardware for processing is required. When using the supplied Rack of Tube Strips for sample homogenization, a suitable microplate centrifuge is required for the lysate clearing step. Alternatively, sample homogenization can be performed in microreaction tubes.

Centrifugation

For processing the 8-well strips under centrifugation, use Starter Set C (see ordering information), containing Column Holders C, NucleoSpin® Dummy Strips, MN Square-well Blocks, and Rack of Tube Strips.

For centrifugation with Column Holder C with inserted NucleoSpin® Plant II Binding Strips stacked on a MN Square-well Block or Rack of Tube Strips, a microtiterplate centrifuge which is able to accommodate the above mentioned sandwich and reach required accelerations of 5,600–6,000 x *g* (bucket height: 85 mm).

Vacuum processing

For processing the 8-well strips under vacuum, use Starter Set A (see ordering information), containing Column Holders A and NucleoSpin® Dummy Strips.

For automation on laboratory platforms with standard 96-well plate manifolds the use of Starter Set A is also required.

2.4 Recommended accessories for use of the NucleoSpin® 8 Plant II Core Kit

The **NucleoSpin® 8 Plant II Core Kit** provides all necessary buffers, enzymes, and NucleoSpin® Binding Strips. Accessories (e.g., lysis plates, waste collection plates, elution plates, or tubes) are not provided with the Core Kit. The reduced kit composition along with a large variety of separately available accessories, allow optimal adjustment of the kit to individual user needs. The user can select additional consumables according to his requirements for highest flexibility.

For use of **NucleoSpin® 8 Plant II Core Kit** follow the standard protocols (see section 5.1 or 5.2, respectively).

Recommended accessories for use of the **NucleoSpin® 8 Plant II Core Kit** are available from MACHEREY-NAGEL. For ordering information please refer to section 6.2.

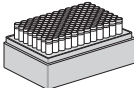
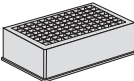
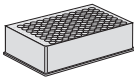
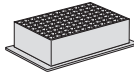
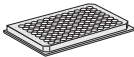
Protocol step	Suitable consumables, not supplied with the core kits		Remarks
1. Homogenize samples	Rack of Tube Strips with Cap Strips		
4. Adjust binding conditions	Square-well Block or Round-well Block or MN Square-well Block	  	For mixing cleared lysate with Buffer PC
7. Wash silica membrane	MN Wash Plates		MN Wash Plate minimizes the risk of cross contamination (vacuum processing)

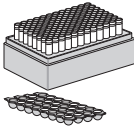
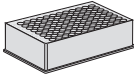
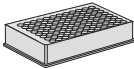
Protocol step	Suitable consumables, not supplied with the core kits	Remarks
8. Elute DNA	Rack of Tubes Strips with Cap Strips or  Round-well Block or  Round-well Block Low (centrifugation only) 	

2.5 Automated processing on robotic platforms

NucleoSpin® 8 Plant II can be used fully automated on many common laboratory workstations. For the availability of scripts and general considerations about adapting **NucleoSpin® 8 Plant II** on a certain workstation please contact MN. Full processing under vacuum enables complete automation without the need for centrifugation steps for drying of the binding membrane or for elution.

The risk of cross-contamination is reduced by optimized vacuum settings during the elution step and by the improved shape of the outlets of the NucleoSpin® Plant II Binding Strips.

Drying the NucleoSpin® Plant II Binding Strips under vacuum is sufficient because the bottom of the strip is protected by the MN Wash Plate during the washing steps. As a result, it is recommended to integrate the MN Wash Plate into the automated procedure to protect against these wash buffer residues. The MN Frame (see ordering information) can be used to position the disposable MN Wash Plate inside the vacuum chamber. This also reduces the risk of cross-contamination as common metal adaptors tend to get contaminated by gDNA. In addition, thorough cleaning of the vacuum chamber is recommended after each run to prevent formation of gDNA-containing aerosols.

Visit MN online at www.mn-net.com or contact your local MACHEREY-NAGEL distributor for technical support regarding hardware, software, setup instructions, and selection of the protocol. Several application notes of the **NucleoSpin® 8 Plant II** kit on various liquid handling instruments can also be found at www.mn-net.com at Bioanalysis/Literature.

2.6 Storage and homogenization of samples

We recommend using young plant samples and keeping the plants in the dark for about 12 h before collecting samples (if possible) in order to reduce the polysaccharide content.

Plant samples can be stored frozen, under ethanol, or lyophilized. In many cases lyophilized, dried material can be processed more easily and gives higher yield. However, keep in mind that dried samples may reduce the amount of starting material by the factor 5 (for example, 20 mg dried plant leaves vs. 100 mg fresh weight).

As plant tissue is very robust, the lysis procedure is most effective with well homogenized, powdered samples. Suitable methods include grinding with pestle and mortar in the presence of liquid nitrogen or using steel beads. We also recommend the use of other commercial homogenizers, bead mills, etc.

Methods to homogenize samples

- Commercial homogenizers, for example Crush Express for 96-well homogenization (Saaten-Union Resistenzlabor GmbH, D-33818 Leopoldshöhe), Tissue Striker (www.KisanBiotech.com), or Geno/Grinder 2000 can be used.
- Samples can be disrupted using bead based homogenization tools, for example, GenoGrinder (<http://www.spexcsp.com> or for Germany www.c3-analysentechnik.de) or Mixer Mill MM400 (<http://www.retsch.com/products/milling/ball-mills/mm-400/>). Please refer to instrument manufacturers recommendations for suitable plates or tubes for homogenization.
- Homogenizing samples by VA steel beads (diameter: 3 mm): Put 4–5 beads and plant material together into a 15 mL plastic tube (Falcon), chill the tube in liquid nitrogen, and vortex for about 30 seconds (e.g., with a Multi Pulse Vortexer, Schütt Labortechnik GmbH, Postfach 3454, D-37024 Göttingen, Germany). Repeat this chilling and vortexing procedure until the entire plant material is ground to a powder. Chill the tube once more and remove the beads by rolling them out gently or remove them with a magnet. Keep the material frozen throughout the whole homogenization procedure. Do not add nitrogen to the tube! This leads to sticking and loss of plant material attached to the beads.
- High-throughput homogenization: Add the plant tissue to the individual tubes of the Tube Strips. Add one 3 mm stainless steel bead to each tube and close the individual tubes with Cap Strips. Freeze the sample in liquid nitrogen and insert the Rack of Tube Strips in a suitable homogenization tool (e.g., mixer mill). For disruption, shake the samples for 60–90 s at 30 Hz or until a homogenous plant powder has been formed. If necessary, repeat shaking once. Fresh plant material can also be homogenized with lysis buffer, however, homogenization of fresh plant material with lysis buffer may cause shearing of DNA. For frozen plant material thawing should be avoided during the homogenization. Samples should be frozen in liquid nitrogen before homogenization. Lyophilized or silica-gel dried material can be homogenized with or without lysis buffer.

Homogenization of lyophilized tissue with lysis buffer may result in higher yield but also may cause shearing of DNA.

2.7 Elution procedures

It is possible to adjust the elution method and the volume of the elution buffer to the specific application of interest. In addition to the standard method (recovery rate about 80–90 %) described in the protocols, there are 3 modifications possible:

- High yields: 90–100 % of bound nucleic acids can be eluted by performing two elution steps with volumes as indicated in the protocol, for example 2 x 100 µL. Finally, combine eluates and measure yield.
- Alternatively use preheated Elution Buffer PE (70 °C): Preheat elution buffer to increase yield. After loading half of the preheated elution buffer (50 µL) onto the membrane, incubate the NucleoSpin® Plant II Binding Strips for 3 min at 60–70 °C. Centrifuge for elution as indicated. Repeat the elution step once.
- Highly concentrated eluates: Using a minimal elution volume (about 50 µL) about 70–80 % of bound nucleic acids can be eluted, resulting in highly concentrated eluates.

Elution may also be performed with Tris-EDTA-buffer (TE) with a pH equal or higher than 8. This will increase DNA stability during long term or multi-use storage at 4 °C (or ambient temperature) by inhibiting omnipresent DNases. However, EDTA interferes, depending on the final concentration, with certain downstream applications.

For optimal performance of isolated DNA in downstream applications, we recommend eluting with the supplied elution buffer and storing it, especially long term, at -20 °C. Several freeze-thaw cycles will not interfere with most downstream applications.

Performance of long-range PCR (e.g., > 10 kbp), or the detection limit of trace amounts of DNA species, may be reduced after multiple freeze-thaw cycles or prolonged storage of eluted DNA at 4 °C or room temperature. This is due to shearing of DNA or adsorption to surfaces.

Due to the dead volume of the silica membrane please note that the difference between the dispensed elution volume and the recovered elution buffer is approximately 45 µL (recovered elution volume = dispensed elution volume – 45 µL).

3 Storage conditions and preparation of working solutions

Attention: Buffer PL1 contains CTAB, Buffer PL2 contains SDS, Buffers PC and PW1 contain chaotropic salt! Wear gloves and goggles!

CAUTION: Buffers PC and PW1 contain guanidine hydrochloride which can form highly reactive compounds when combined with bleach (sodium hypochlorite). DO NOT add bleach or acidic solutions directly to the sample-preparation waste.

- Store **RNase A** at 4 °C on arrival (storage at 4 °C may cause precipitation of salts in different buffers).
- All other components can be stored at room temperature (18–25 °C) and are stable for up to 1 year.

Before starting any **NucleoSpin® 8 Plant II** protocol prepare the following:

- **Lysis Buffer PL2:** Check for precipitated SDS especially after storage at temperatures below 20 °C. If necessary incubate the bottle for several minutes at 30–40 °C and mix well until the precipitate is redissolved completely.
- **Wash Buffer PW2:** Add the indicated volume of ethanol (96–100 %) to Buffer PW2 Concentrate before first use. Store Buffer PW2 at room temperature (18–25 °C) for up to one year.
- **RNase A:** Add the given volume of water (indicated on the vial, see below) to lyophilized RNase A. Store the RNase A solution at 4 °C for up to 3 months. For longer storage (up to 1 year), the RNase A solution should be divided into small aliquots and stored at -20 °C.

	NucleoSpin® 8 Plant II	NucleoSpin® 8 Plant II	NucleoSpin® 8 Plant II Core Kit
REF	12 x 8 preps 740669	60 x 8 preps 740669.5	48 x 8 preps 740467.4
Wash Buffer PW2 (Concentrate)	40 mL Add 160 mL ethanol	200 mL Add 800 mL ethanol	150 mL Add 600 mL ethanol
RNase A (lyophilized)	15 mg Add 1.25 mL H ₂ O	3 x 30 mg Add 2.5 mL H ₂ O to each vial	30 mg Add 2.5 mL H ₂ O

4 Safety instructions – risk and safety phrases

The following components of the NucleoSpin® 8 Plant II and NucleoSpin® 8 Plant II Core kits contain hazardous contents.

Wear gloves and goggles and follow the safety instructions given in this section.

4.1 Risk and safety phrases

Component	Hazard contents	Hazard symbol	Risk phrases	Safety phrases
Inhalt	Gefahrstoff	Gefahrstoffsymbol	R-Sätze	S-Sätze
PC	Guanidinium hydrochloride + ethanol <i>Guanidiniumhydrochlorid + Ethanol</i>	✘ Xn*	R 10-22	S 16
PW1	Guanidinium hydrochloride + iso-propanol <i>Guanidiniumhydrochlorid + Isopropanol</i>	✘ Xn*	R 10-22-36	S 16-26-39
RNase A	RNase A, lyophilized <i>RNase A, lyophilisiert</i>	✘ Xn	R 42/43	S 22-24

Risk phrases

- R 10 Flammable.
Leichtentzündlich
- R 22 Harmful if swallowed.
Gesundheitsschädlich beim Verschlucken.
- R 36 Irritating to the skin.
Reizt die Haut.
- R 42/43 May cause sensitization by inhalation and skin contact.
Sensibilisierung durch Einatmen und Hautkontakt möglich.



Safety phrases

- S 16 Keep away from sources of ignition – No smoking!
Von Zündquellen fernhalten – Nicht rauchen!
- S 22 Do not breathe dust.
Staub nicht einatmen.
- S 24 Avoid contact with the skin.
Berührung mit der Haut vermeiden.
- S 26 In case of contact with eyes, rinse immediately with plenty of water and seek medical advice.
Bei Berührung mit den Augen sofort gründlich mit Wasser abspülen und Arzt konsultieren.
- S 39 Wear eye / face protection.
Schutzbrill / Gesichtsschutz tragen.

* Hazard labeling not necessary if quantity per bottle below 125 g or mL (certificate of exemption according to 67/548/EEC Art. 25, 1999/45/EC Art. 12 and German GefStoffV § 20 (3) and TRGS 200 7.1). For further information see Material Safety Data Sheet.

4.2 GHS classification

Only harmful features need not be labeled with H and P phrases until 125 mL or 125 g.
Mindergefährliche Eigenschaften müssen bis 125 mL oder 125 g nicht mit H- und P-Sätzen gekennzeichnet werden.

Component	Hazard contents	GHS symbol	Hazard phrases	Precaution phrases
<i>Inhalt</i>	<i>Gefahrstoff</i>	<i>GHS Symbol</i>	<i>H-Sätze</i>	<i>P-Sätze</i>
PC	Guanidinium hydrochloride 24–36 % + ethanol 35–55 % <i>Guanidiniumhydrochlorid 24–36 % + Ethanol 35–55 %</i>	 Warning Achtung	226, 302	210, 233, 301+312, 330, 403+235
PW1	Guanidinium hydrochloride 36–50 % + isopropanol 20–50 % <i>Guanidiniumhydrochlorid 36–50 % + Isopropanol 20–50 %</i>	 Warning Achtung	226, 302, 319	210, 233, 280, 301+312, 305+351+338, 330, 337+313, 403+235
RNase A	RNase A, lyophilized <i>RNase A, lyophilisiert</i>	 Danger Gefahr	317, 334	261, 304+341, 342+311, 301+312, 280, 302+352, 333+313

Hazard phrases

- H 226 Flammable liquid and vapour.
Flüssigkeit und Dampf entzündbar.
- H 302 Harmful if swallowed.
Gesundheitsschädlich bei Verschlucken.
- H 317 May cause an allergic skin reaction.
Kann allergische Hautreaktionen verursachen.
- H 319 Causes serious eye irritation.
Verursacht schwere Augenreizung.
- H 334 May cause allergy or asthma symptoms or breathing difficulties if inhaled.
Kann bei Einatmen Allergie, asthmaartige Symptome oder Atembeschwerden verursachen.

Precaution phrases

- P 210 Keep away from heat / sparks / open flames / hot surfaces – No smoking.
Von Hitze / Funken / offener Flamme / heißen Oberflächen fernhalten. Nicht rauchen.
- P 233 Keep container tightly closed.
Behälter dicht verschlossen halten.
- P 261 Avoid breathing dust.
Einatmen von Staub vermeiden.
- P 280 Wear protective gloves / eye protection.
Schutzhandschuhe / Augenschutz tragen.
- P 301+312 IF SWALLOWED: Call a POISON CENTER or doctor / physician if you feel unwell.
Bei Verschlucken: Bei Unwohlsein Giftinformationszentrum oder Arzt anrufen.
- P 302+352 IF ON SKIN: Wash with plenty of soap and water.
Bei Kontakt mit der Haut: Mit viel Wasser und Seife waschen.
- P 304+341 IF INHALED: If breathing is difficult, remove to fresh air and keep at rest in a position comfortable for breathing.
Bei Einatmen: Bei Atembeschwerden an die frische Luft bringen und in einer Position ruhigstellen, die das Atmen erleichtert.
- P 305+351+338 IF IN EYES: Rinse continuously with water for several minutes. Remove contact lenses if present and easy to do – continue rinsing.
Bei Kontakt mit den Augen: Einige Minuten lang behutsam mit Wasser spülen. Vorhandene Kontaktlinsen nach Möglichkeit entfernen. Weiter spülen.
- P 330 Rinse mouth.
Mund ausspülen.
- P 333+313 If skin irritation occurs: Get medical advice / attention.
Bei Hautreizung: Ärztlichen Rat einholen / ärztliche Hilfe hinzuziehen.
- P 337+313 Get medical advice / attention.
Bei anhaltender Augenreizung: Ärztlichen Rat einholen / ärztliche Hilfe hinzuziehen.
- P 342+311 If experiencing respiratory symptoms: Call a POISON CENTER or doctor / physician.
Bei Symptomen der Atemwege: Giftinformationszentrum oder Arzt anrufen.
- P 403+235 Store in a well ventilated place. Keep cool.
Kühl an einem gut belüfteten Ort aufbewahren.

For further information please see Material Safety Data Sheets (www.mn-net.com).
Weiterführende Informationen finden Sie in den Sicherheitsdatenblättern (www.mn-net.com).

5 Protocols

5.1 NucleoSpin® 8 Plant II – centrifuge processing

- For hardware requirements, refer to section 2.3.
- For detailed information on each step, see page 18.
- For use of the NucleoSpin® 8 Plant II Core Kit (REF 740467.4), refer to section 2.4 regarding recommended accessories.

Before starting the preparation:

- Check if Buffer PW2 and RNase A were prepared according to section 3.
- Set incubator or oven to 65 °C.
- Equilibrate Buffer PE to 70 °C.

Protocol-at-a-glance

1	Homogenize samples	<p>Up to 100 mg wet or 20 mg lyophilized plant tissue</p> <p>5,600–6,000 x g, 2 min</p>
2 a	Cell lysis using Buffer <u>PL1</u>	<p>500 µL PL1 10 µL RNase A</p> <p>Mix</p> <p>65 °C, 30 min</p> <p>Proceed with step 3</p>
2 b	Cell lysis using Buffer <u>PL2</u> and <u>PL3</u>	<p>400 µL PL2 10 µL RNase A</p> <p>Mix</p> <p>65 °C, 30 min</p> <p>100 µL PL3</p> <p>Mix and incubate on ice for 5 min</p> <p>Proceed with step 3</p>

3	Clear lysate by centrifugation	5,600–6,000 x g, 20 min
4	Adjust binding conditions	Mix 450 µL PC with 400 µL cleared lysate
5	Transfer lysate to NucleoSpin® Plant II Binding Strips	
6	Bind DNA to silica membrane of the NucleoSpin® Plant II Binding Strips	5,600–6,000 x g, 2 min
7	Wash and dry silica membrane	400 µL PW1 5,600–6,000 x g, 2 min 700 µL PW2 5,600–6,000 x g, 2 min 700 µL PW2 5,600–6,000 x g, 10 min
8	Elute DNA	100 µL PE (70 °C) (incubate 2 min) 5,600–6,000 x g, 2 min Repeat once

Detailed protocol

- For hardware requirements, refer to section 2.3.
- For use of the NucleoSpin® 8 Plant II Core Kit (REF 740467.4), refer to section 2.4 regarding recommended accessories.

Before starting the preparation:

- Check if Buffer PW2 and RNase A were prepared according to section 3.
 - Set incubator or oven to 65 °C.
 - Equilibrate Buffer PE to 70 °C.
-

1 Homogenize samples

Fill **up to 100 mg wet plant tissue** (or up to **20 mg dried material**, for example lyophilized plant tissue) into each tube of the Tube Strips. Add one 3 mm diameter steel bead (not provided) to each tube. Close the tubes with Cap Strips. Freeze samples in liquid nitrogen. Disrupt cells by vigorous shaking using a mixer mill. Centrifuge at **5,600 x g** for **2 min** and remove Cap Strips.

For further processing use either Buffer PL1 (2 a) or Buffers PL2/PL3 (2 b)!

2a Cell lysis using Buffer PL1

Add **500 µL Buffer PL1** and **10 µL RNase A** to each sample. Close tubes again using new Cap Strips (supplied). Mix by vigorous **shaking** for **15–30 s**. **Spin briefly for 30 s** at **1,500 x g** to collect any sample from the Cap Strips. Incubate samples at **65 °C for 30 min**.

Depending on plant sample and available methods, Buffer PL1 and RNase A may be added to the plant material before homogenization by the appropriate mechanical method.

Proceed with step 3.

2b Cell lysis using Buffer PL2 and PL3

Add **400 µL Buffer PL2** and **10 µL RNase A** to each sample. Close tubes again using new Cap Strips (supplied). Mix by vigorous **shaking** for **15–30 s**. **Spin briefly for 30 s** at **1,500 x g** to collect any sample from the Cap Strips. Incubate samples at **65 °C for 30 min**.

Depending on plant sample and available methods, Buffer PL2 and RNase A may be added to the plant material before homogenization by the appropriate mechanical method.

Open tubes, add **100 µL Buffer PL3** to each well, close tubes, mix thoroughly, and incubate for 5 min on ice to precipitate SDS completely.

3 Clear lysate by centrifugation

Centrifuge the samples for **20 min** at **full speed (5,600–6,000 x g)**. Remove Cap Strips.

4 Adjust binding conditions

Pre-dispense **450 µL Binding Buffer PC** to each well of an MN Square-well Block. Add **400 µL cleared lysate** of each sample and mix by repeated pipetting up and down. Mix at least 3 times.

5 Transfer lysate to NucleoSpin® Plant II Binding Strips

Insert desired number of NucleoSpin® Plant II Binding Strips into the Column Holder C and place it on an MN Square-well Block for collection of flow-through. If using more than one block, label the column holders for later identification.

Transfer samples from the previous step into the wells of the NucleoSpin® Plant II Binding Strips. Do not moisten the rims of the individual wells while dispensing the samples.

Optional: Seal openings of the binding strips with a Gas-permeable Foil.

6 Bind DNA to silica membrane

Place the Column Holder C, with stacked NucleoSpin® Plant II Binding Strips, onto a MN Square-well Block in the rotor buckets. Centrifuge at **5,600–6,000 x g** for 5 min.

Note: The Column Holder C containing the NucleoSpin® Plant II Binding Strips is usually loosely sitting on top of the MN Square-well Block.

Typically, lysates will pass through the columns within 1 min, however, the centrifugation process can be extended up to 20 min if the lysates have not completely passed.

Note: The volumes of each well of the NucleoSpin® Plant II Binding Strips is approximately 1 mL. Higher volumes, resulting from steps 1–3, have to be loaded successively until the complete lysis mixture has been applied.

7 Wash silica membrane

1st wash

Add **400 µL PW1** to each well of the NucleoSpin® Plant II Binding Strips.

Seal strips with a Gas-permeable Foil and centrifuge again at **5,600–6,000 x g** for **2 min**. Discard collected waste from previous steps to waste.

2nd wash

Add **700 µL PW2** to each well of the NucleoSpin® Plant II Binding Strips.

Seal strips with a Gas-permeable Foil and centrifuge again at **5,600–6,000 x g** for **2 min**. Discard collected waste to waste.

3rd wash

Add **700 µL PW2** to each well of the NucleoSpin® Plant II Binding Strips.

Seal strips with a Gas-permeable Foil and centrifuge again at **5,600–6,000 x g** for **2 min**. Discard collected waste to waste.

Note: For critical ethanol-sensitive applications, it is recommended to prolong the centrifugation time up to 15 min or incubate at higher temperature. Remove the adhesive foil and place the NucleoSpin® Plant II Binding Strips into an incubator for 20 min at 37 °C to evaporate residual ethanol.

8 Elute DNA

Place the Column Holder C with NucleoSpin® Plant II Binding Strips on the Rack of Tube Strips. Dispense **100 µL pre-heated Buffer PE (70 °C)** to each well of the NucleoSpin® Plant II Binding Strips. Dispense the buffer directly onto the membrane.

Optional: Incubate for 2 min at 70 °C before centrifugation.

Centrifuge at **5,600–6,000 x g** for 2 min.

For optimal yield it is recommended to repeat this step once (incubation of Buffer PE on the membrane not required)

Yields will be 10–20 % higher when eluting with 2 x 100 µL Buffer PE, depending on the total amount of DNA. However, the concentration of DNA will be much lower than with 100 µL.

Note: Elution can be done with TE buffer (at least pH 8.0) as well. Elution efficiency will decrease when using elution buffers with pH ≤ 8.0.

5.2 NucleoSpin® 8 Plant II – vacuum processing

- For hardware requirements, refer to section 2.3.
- For detailed information on each step see page 24.
- For detailed information regarding the vacuum manifold set-up see page 23.
- For use of the NucleoSpin® 8 Plant II Core Kit (REF 740467.4), refer to section 2.4 regarding recommended accessories.

Before starting the preparation:

- Check if Buffer PW2 and RNase A were prepared according to section 3.
- Set incubator or oven to 65 °C.
- Equilibrate Buffer PE to 70 °C.

Protocol-at-a-glance

1	Homogenize samples	<p>Up to 100 mg wet or 20 mg lyophilized plant tissue</p> <p>5,600–6,000 x g, 2 min</p>
2a	Cell lysis using Buffer <u>PL1</u>	<p>500 µL PL1 10 µL RNase A</p> <p>Mix</p> <p>65 °C, 30 min</p> <p>Proceed with step 3</p>
2b	Cell lysis using Buffer <u>PL2</u> and <u>PL3</u>	<p>400 µL PL2</p> <p>Mix</p> <p>65 °C, 30 min</p> <p>100 µL PL3</p> <p>Mix and incubate on ice for 5 min</p> <p>Proceed with step 3</p>

3	Clear lysate by centrifugation	5,000–6,000 x g 20 min
4	Adjust binding conditions	Mix 450 µL PC with 400 µL cleared lysate
5	Transfer lysate to NucleoSpin® Plant II Binding Strips	
6	Bind DNA to silica membrane of the NucleoSpin® Plant II Binding Strips	-0.2 to -0.4 bar* (2 min)
7	Wash and dry silica membrane	400 µL PW1 700 µL PW2 700 µL PW2 -0.4 bar* (1 min each step)
		Remove MN Wash Plate
		Dry silica membrane (10 min, maximum vacuum)
8	Elute DNA	100 µL PE (incubate 2 min) -0.4 bar* (2 min) Repeat once

* Reduction of atmospheric pressure

Setup of vacuum manifold:

Binding / Washing steps

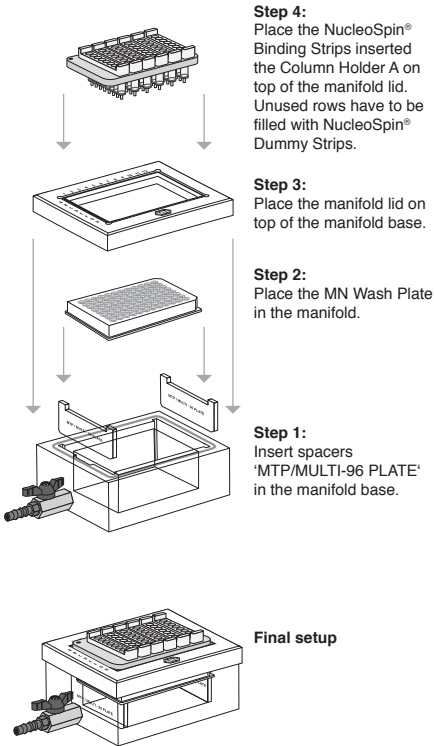

Elution step

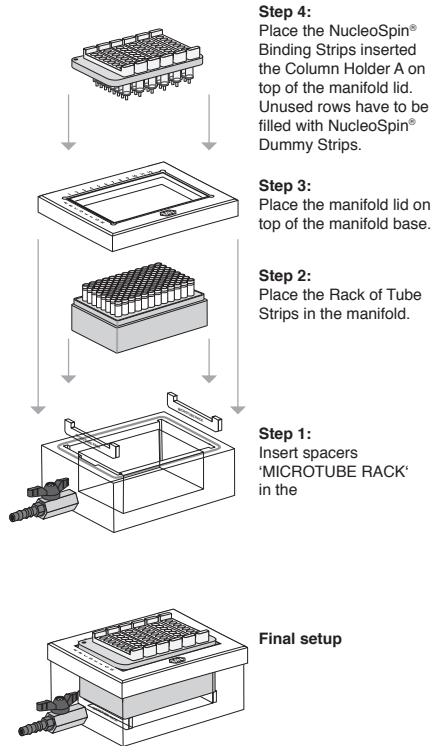

Detailed protocol

- For hardware requirements, refer to section 2.3.
- For detailed information regarding the vacuum manifold set-up see page 23.
- For use of the NucleoSpin® 8 Plant II Core Kit (REF 740467.4), refer to section 2.4 regarding recommended accessories.

Before starting the preparation:

- Check if Buffer PW2 and RNase A were prepared according to section 3.
 - Set incubator or oven to 65 °C.
 - Equilibrate Buffer PE to 70 °C.
-

1 Homogenize samples

Fill **up to 100 mg wet plant tissue** (or up to **20 mg dried, for example lyophilized, plant tissue**) into each tube of the Tube Strips. Add one 3 mm diameter steel bead to each tube. Close the tubes with Cap Strips. Freeze samples in liquid nitrogen. Disrupt cells by vigorous shaking using a mixer mill. Spin at **5,600 x g** for **2 min** and remove Cap Strips.

For further processing use either Buffer PL1 (2 a) or Buffers PL2 / PL3 (2 b)!

2a Cell lysis using Buffer PL1

Add **500 µL Buffer PL1** and **10 µL RNase A** to each sample. Close tubes again using new Cap Strips (supplied). Mix by vigorous **shaking** for **15–30 s**. **Spin briefly** for **30 s** at **1,500 x g** to collect any sample from the Cap Strips. Incubate samples at **65 °C** for **30 min**.

Depending on plant sample and available methods, Buffer PL1 and RNase A may be added to the plant material before homogenization by the appropriate mechanical method.

Proceed with step 3.

2b Cell lysis using Buffer PL2 and PL3

Add **400 µL Buffer PL2** and **10 µL RNase A** to each sample. Close tubes again using new Cap Strips (supplied). Mix by vigorous **shaking** for **15–30 s**. **Spin briefly** for **30 s** at **1,500 x g** to collect any sample from the Cap Strips. Incubate samples at **65 °C** for **30 min**.

Depending on plant sample and available methods, Buffer PL2 and RNase A may be added to the plant material before homogenization by the appropriate mechanical method.

Open tubes, add **100 µL Buffer PL3**, close tubes, mix thoroughly, and incubate for 5 min on ice to precipitate SDS completely.

3 Clear lysate by centrifugation

Centrifuge the samples for **20 min at full speed (5,600–6,000 x g)**. Remove Cap Strips.

4 Adjust binding conditions

Pre-dispense **450 µL Binding Buffer PC** to each well of an MN Square-well Block. Add **400 µL cleared lysate** of each sample and mix by repeated pipetting up and down. Mix at least 3 times.

5 Transfer lysate to NucleoSpin® Plant II Binding Strips

Insert appropriate number of NucleoSpin® Plant II Binding Strips into a Column Holder A. Close any unused openings of the Column Holder A with NucleoSpin® Dummy Strips.

Note: Make sure that the NucleoSpin® Plant II Binding Strips are inserted tightly into the column holder. Not properly inserted strips may prevent sealing when vacuum is applied to the manifold.

Insert spacers ('MTP/MULTI-96 PLATE'), notched side up, into the grooves located on the short sides of the manifold. Insert the waste reservoir into the center of the manifold. Put the MN Wash Plate on the spacers in the manifold base. Insert Column Holder A with inserted NucleoSpin® Plant II Binding Strips into the manifold lid and place lid on the manifold base.

Transfer samples from the previous step into the wells of the NucleoSpin® Plant II Binding Strips. Do not moisten the rims of the individual wells while dispensing the samples.

6 Bind DNA to silica membrane

Apply vacuum of **-0.2 to -0.4 bar*** to allow samples to pass through the membrane. Flow-through rate should be about 1–2 drops per second. Adjust vacuum strength accordingly. Finally, release the vacuum.

* Reduction of atmospheric pressure

7 Wash silica membrane

1st wash

Add **400 µL PW1** to each well of the NucleoSpin® Plant II Binding Strips and apply vacuum of **-0.2 to -0.4 bar*** until the buffer has passed the membrane completely. Release the vacuum.

2nd wash

Add **700 µL PW2** to each well of the NucleoSpin® Plant II Binding Strips and apply vacuum of **-0.2 to -0.4 bar*** until the buffer has passed the membrane completely. Release the vacuum.

3rd wash

Add **700 µL PW2** to each well of the NucleoSpin® Plant II Binding Strips and apply vacuum of **-0.2 to -0.4 bar*** until the buffer has passed the membrane completely. Release the vacuum.

Remove MN Wash Plate and waste tray.

Reassemble the vacuum manifold and dry the membrane by applying maximum vacuum (**-0.6 bar***) for 10 minutes.

8 Elute DNA

Insert spacers '*MICROTUBE RACK*' into the vacuum manifold base. Place the Rack of Tube Strips into the manifold base. Close the manifold and insert the Column Holder A with NucleoSpin® Plant II Binding Strips into the manifold top. Dispense **100 µL pre-heated Buffer PE (70 °C)** to each well of the NucleoSpin® Plant II Binding Strips. Dispense the buffer directly onto the membrane. Incubate at room temperature for 2 min. Apply vacuum of **-0.4 bar*** until the elution buffer has passed the membrane completely.

For optimal yield it is recommended to repeat this step once (incubation of Buffer PE on the membrane not required)

Yields will be 10–20 % higher when eluting with 2 x 100 µL Buffer PE depending on the total amount of DNA. However, the concentration of DNA will be much lower than with 100 µL.

Note: Elution can be done with TE buffer (at least pH 8.0) as well. Elution efficiency will decrease when using elution buffers with pH ≤ 8.0.

* Reduction of atmospheric pressure

6 Appendix

6.1 Troubleshooting

Problem	Possible cause and suggestions
DNA yield is low	<p><i>Homogenization of plant material was not sufficient</i></p> <ul data-bbox="309 379 981 579" style="list-style-type: none"> • For most species we recommend grinding with steel beads. Homogenization should be done thoroughly until the plant material is ground to a fine powder. In most cases this can be achieved by vigorous shaking for 3 x 60 s with occasional freezing in liquid nitrogen. • This problem can also be avoided by lyophilizing the material. This way, it will be easier to grind the material.
	<p><i>Extraction of DNA from plant material during lysis was not sufficient</i></p> <ul data-bbox="309 652 981 703" style="list-style-type: none"> • To obtain higher yields of DNA, the incubation time in lysis buffer can be prolonged (up to overnight).
	<p><i>Suboptimal lysis buffer was used</i></p> <ul data-bbox="309 777 981 884" style="list-style-type: none"> • Lysis efficiencies of Buffer PL1 (CTAB) and Buffer PL2 (SDS) are different and depend on the plant species. Try both buffers in a side-by side purification to find the best detergent system to lyse your plant material.
	<p><i>Sample contains too much RNA</i></p> <ul data-bbox="309 957 981 1064" style="list-style-type: none"> • Add 10 µL of RNase A solution to the Lysis Buffer PL1 or PL2 before heat incubation. If this is not successful, add the enzyme to the cleared supernatant of step 3 and incubate for 30 min at 60 °C.
DNA is degraded	<p><i>Sub-optimal Elution</i></p> <ul data-bbox="309 1137 981 1310" style="list-style-type: none"> • The DNA can be either eluted in higher volumes (up to 300 µL) or by repeating the elution step up to three times. Remember that the elution buffer must be preheated to 70 °C prior to elution. • Also check the pH of the elution buffer used, which should be in a range of pH 8–8.5. To ensure correct pH, use supplied elution Buffer PE.
	<p><i>Sample was contaminated with DNase</i></p> <ul data-bbox="309 1383 981 1434" style="list-style-type: none"> • Check bench, pipettes and storage of sample in order to avoid DNase contamination.

Problem	Possible cause and suggestions
DNA purity is low	<p><i>Sample contains DNA-degrading contaminants (e.g., phenolic compounds, secondary metabolites)</i></p> <ul style="list-style-type: none"> Repeat washing step with Buffer PW1.
	<p><i>Elution buffer contains EDTA</i></p> <ul style="list-style-type: none"> EDTA can disturb subsequent reactions. Use of water or supplied Elution Buffer PE is highly recommended.

6.2 Ordering information

Product	REF	Pack of
NucleoSpin® 8 Plant II	740669	12 x 8 preps
	740669 .5	60 x 8 preps
NucleoSpin® 8 Plant II Core Kit	740467 .4	48 x 8 preps
NucleoSpin® 96 Plant II	740663 .2	1 x 96 preps
	740663 .4	4 x 96 preps
	740663 .24	24 x 96 preps
NucleoSpin® 96 Plant II Core Kit	740468 .4	4 x 96 preps
Buffer PL1	740918	125 mL
Buffer Set PL2/PL3 (100 mL Buffer PL2 + 25 mL Buffer PL3)	740919	1 set
Buffer PC	740937	125 mL
Buffer PW1	740938	125 mL
Buffer PW2 Concentrate (for 1 L Buffer PW2)	740939	50 mL
RNase A (lyophilized)	740505	100 mg
	740505 .50	50 mg
Proteinase K	740506	100 mg

Product	REF	Pack of
MN Square-well Block	740476	4
	740476 .24	24
MN Wash Plate	740479	4
	740479 .24	24
Rack of Tube Strips (1 set consists of 1 rack, 12 strips with 8 tubes each, and 12 Cap Strips)	740477	4 sets
	740477 .24	24 sets
Cap Strips	740478	48
	740478 .24	288
Gas-permeable Foil	740675	50
NucleoVac 96 Vacuum Manifold	740681	1
NucleoVac Vacuum Regulator	740641	1
Starter Set A (for processing NucleoSpin® 8-well strips on NucleoVac 96 Vacuum Manifold)	740682	1
Starter Set C (for processing NucleoSpin® 8-well strips under centrifugation)	740684	1

Visit www.mn-net.com for more detailed product information.

6.3 Product use restriction/warranty

NucleoSpin® 8 Plant II (Core Kit) components are intended, developed, designed, and sold FOR RESEARCH PURPOSES ONLY, except, however, any other function of the product being expressly described in original MACHEREY-NAGEL product leaflets.

MACHEREY-NAGEL products are intended for GENERAL LABORATORY USE ONLY! MACHEREY-NAGEL products are suited for QUALIFIED PERSONNEL ONLY! MACHEREY-NAGEL products shall in any event only be used wearing adequate PROTECTIVE CLOTHING. For detailed information please refer to the respective Material Safety Data Sheet of the product! MACHEREY-NAGEL products shall exclusively be used in an ADEQUATE TEST ENVIRONMENT. MACHEREY-NAGEL does not assume any responsibility for damages due to improper application of our products in other fields of application. Application on the human body is STRICTLY

FORBIDDEN. The respective user is liable for any and all damages resulting from such application.

DNA/RNA/PROTEIN purification products of MACHEREY-NAGEL are suitable for *IN VITRO*-USES ONLY!

ONLY MACHEREY-NAGEL products specially labeled as IVD are also suitable for *IN VITRO*-diagnostic use. Please pay attention to the package of the product. *IN VITRO*-diagnostic products are expressly marked as IVD on the packaging.

IF THERE IS NO IVD SIGN, THE PRODUCT SHALL NOT BE SUITABLE FOR *IN VITRO*-DIAGNOSTIC USE!

ALL OTHER PRODUCTS NOT LABELED AS IVD ARE NOT SUITED FOR ANY CLINICAL USE (INCLUDING, BUT NOT LIMITED TO DIAGNOSTIC, THERAPEUTIC AND/OR PROGNOSTIC USE).

No claim or representations is intended for its use to identify any specific organism or for clinical use (included, but not limited to diagnostic, prognostic, therapeutic, or blood banking). It is rather in the responsibility of the user or - in any case of resale of the products - in the responsibility of the reseller to inspect and assure the use of the DNA/RNA/protein purification products of MACHEREY-NAGEL for a well-defined and specific application.

MACHEREY-NAGEL shall only be responsible for the product specifications and the performance range of MN products according to the specifications of in-house quality control, product documentation and marketing material.

This MACHEREY-NAGEL product is shipped with documentation stating specifications and other technical information. MACHEREY-NAGEL warrants to meet the stated specifications. MACHEREY-NAGEL's sole obligation and the customer's sole remedy is limited to replacement of products free of charge in the event products fail to perform as warranted. Supplementary reference is made to the general business terms and conditions of MACHEREY-NAGEL, which are printed on the price list. Please contact us if you wish to get an extra copy.

There is no warranty for and MACHEREY-NAGEL is not liable for damages or defects arising in shipping and handling (transport insurance for customers excluded), or out of accident or improper or abnormal use of this product; defects in products or components not manufactured by MACHEREY-NAGEL, or damages resulting from such non-MACHEREY-NAGEL components or products.

MACHEREY-NAGEL makes no other warranty of any kind whatsoever, and SPECIFICALLY DISCLAIMS AND EXCLUDES ALL OTHER WARRANTIES OF ANY KIND OR NATURE WHATSOEVER, DIRECTLY OR INDIRECTLY, EXPRESS OR IMPLIED, INCLUDING, WITHOUT LIMITATION, AS TO THE SUITABILITY, REPRODUCTIVITY, DURABILITY, FITNESS FOR A PARTICULAR PURPOSE OR USE, MERCHANTABILITY, CONDITION, OR ANY OTHER MATTER WITH RESPECT TO MACHEREY-NAGEL PRODUCTS.

In no event shall MACHEREY-NAGEL be liable for claims for any other damages, whether direct, indirect, incidental, compensatory, foreseeable, consequential, or special (including but not limited to loss of use, revenue or profit), whether based upon warranty, contract, tort (including negligence) or strict liability arising in connection with

the sale or the failure of MACHEREY-NAGEL products to perform in accordance with the stated specifications. This warranty is exclusive and MACHEREY-NAGEL makes no other warranty expressed or implied.

The warranty provided herein and the data, specifications and descriptions of this MACHEREY-NAGEL product appearing in MACHEREY-NAGEL published catalogues and product literature are MACHEREY-NAGEL's sole representations concerning the product and warranty. No other statements or representations, written or oral, by MACHEREY-NAGEL's employees, agent or representatives, except written statements signed by a duly authorized officer of MACHEREY-NAGEL are authorized; they should not be relied upon by the customer and are not a part of the contract of sale or of this warranty.

Product claims are subject to change. Therefore please contact our Technical Service Team for the most up-to-date information on MACHEREY-NAGEL products. You may also contact your local distributor for general scientific information. Applications mentioned in MACHEREY-NAGEL literature are provided for informational purposes only. MACHEREY-NAGEL does not warrant that all applications have been tested in MACHEREY-NAGEL laboratories using MACHEREY-NAGEL products. MACHEREY-NAGEL does not warrant the correctness of any of those applications.

Last updated: 07/2010, Rev. 03

Please contact:

MACHEREY-NAGEL GmbH & Co. KG

Tel.: +49 (0) 24 21 969 270

e-mail: tech-bio@mn-net.com

Trademarks/disclaimer:

NucleoSpin® is a registered trademark of MACHEREY-NAGEL GmbH & Co. KG

All used names and denotations can be brands, trademarks, or registered labels of their respective owner – also if they are not special denotation. To mention products and brands is only a kind of information (i.e., it does not offend against trademarks and brands and can not be seen as a kind of recommendation or assessment). Regarding these products or services we can not grant any guarantees regarding selection, efficiency, or operation.